

Capistrano Unified School District

4th Grade Beginning Strings -Cello-



With input and materials from: Kerry Arakawa, Scott Arakawa, Steve Benefield, Michelle Brunton, Penni Buff, Chad Cunningham, Lisa Gray, Andrea Howard, Ann Ludwig, Barbara Scholl, Rob Stirling, Maryann Tucker, and Kory Wentzel.

Name: _____ **School:** _____

Classroom Teacher: _____

Parts of the Cello

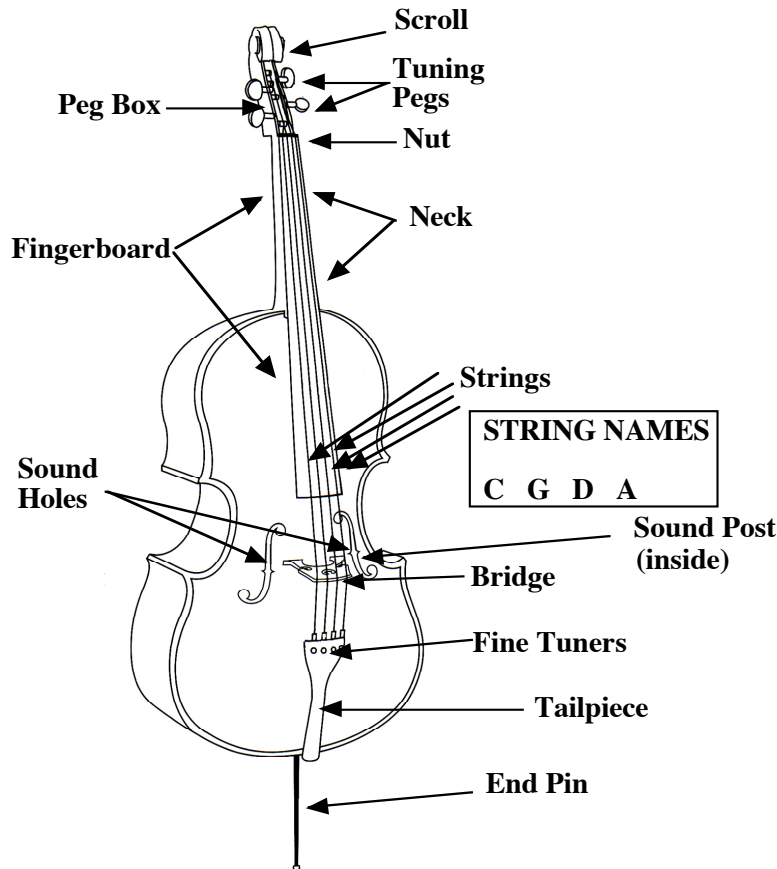

Taking Care of Your Cello

Handle With Care! Your instrument is made of breakable wooden parts, so repairs can be expensive and time consuming.

Do not let anyone play your instrument unless it is your teacher or an experienced player you trust.

Always take the bow out first. Before taking your cello out, take the bow out of the pocket of the case.

Keep your instrument clean! After playing, wipe off the rosin dust, smudges, fingerprints, etc., with a soft clean cloth. Always wash your hands before playing your instrument.

Do not let your instrument get too hot or too cold. If the temperature is uncomfortable for you, it is also bad for your instrument. For example, never leave your instrument in a car on a hot or cold day.

Allow only an experienced repair person to fix your instrument.

Make sure your bridge is lined up correctly and standing straight at all times. If it gets out of place, ask your teacher to fix it for you.

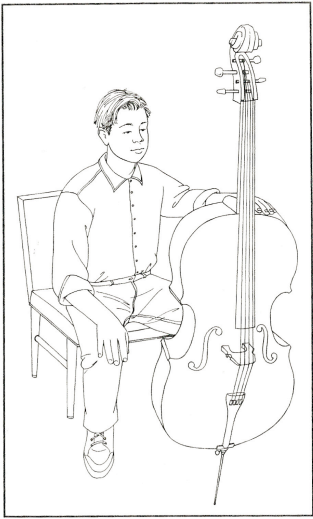

Lesson One: Getting Started

Holding your Cello

1. Pull the end pin out far enough to make the scroll of the cello at least as high as your chin when you are standing
2. Sit “tall” on the front edge of your chair with your knees bent and your left foot slightly forward. If you are sitting correctly, you can stand up quickly and easily.
3. While holding your cello straight up and down, and at arm’s length, center the end pin in front of you.
4. Bring your cello toward you so the upper edge touches the center of your chest. The lowest peg should be touching your head behind your left ear.
5. The inside of both knees touch the sides of your cello. Do not grip the cello with your knees.
6. If your position is correct, you should be feel relaxed and balanced in your chair and to be able to move side to side easily.

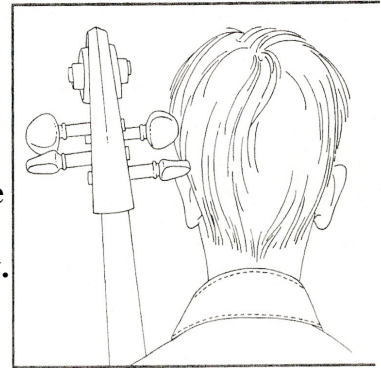

Pizzicato Position

1. Place the tip of your right thumb on the side of the fingerboard (near the corner).
2. Extend your first finger over the fingerboard and pluck the string.
3. For the best sound, make the string vibrate as much as possible.

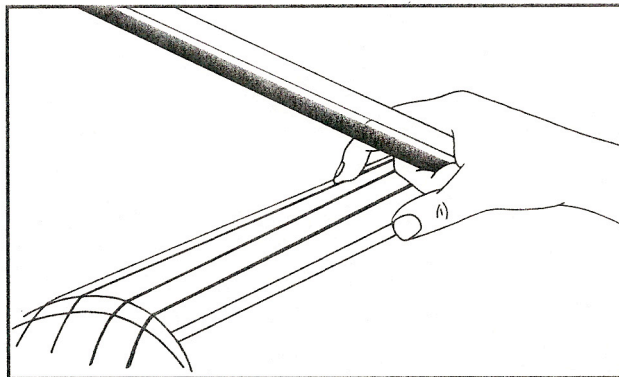

The Cello has four open strings.
 They are named from lowest to highest,
 left to right, and thick to thin. This sentence
 will help you remember which order they are in:
Cats Get Dogs Angry.

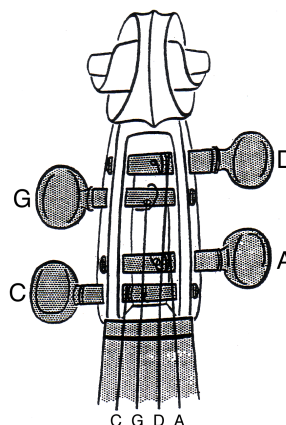

Let's Review how to hold the cello in playing position.

1. Sit tall.
2. Cello makes contact with the floor, knees, and chest
3. Check the end pin is out far enough so that the C-peg is behind your left ear
4. Give cello a hug to center it in your body
5. Left hand rests on left knee

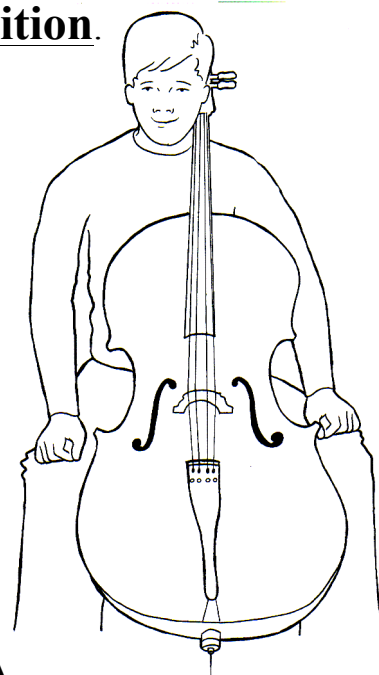

1. Rock House

D D D D D D D D D D D D D D D D

2. Rock Hound

A A A A A A A A A A A A A A A A

3. Rock Tango

D D A A D D A A A A D D A A D D

4. The Twist

G G D D G G D D A A D D G G G G

5. Lazy Afternoon

G G D D A A D D G G D D A A G G

6. Skip to My Lou

D D D D A A A A D D D D A A D D

7. Mary Had a Little Lamb

D D D D D D D D A A A A D D D D

D D D D D D D D A A A A D - D -

8. Cycle of Strings

⏏ = Quarter Rest (one beat of silence)

⏏ ⏏ ⏏ ⏏ A A A A D D D D G G G G C C C C
 C C C C G G G G D D D D A A A A ⏏ ⏏ ⏏ ⏏

*Pencil Fun- Do You Remember the Parts of the Cello?

1. _____

2. _____

3. _____

4. _____

5. _____

6. _____

7. _____

8. _____

9. _____

10. _____

11. _____

12. _____

13. _____

1. _____

2. _____

3. _____

4. _____

5. _____

6. _____

7. _____

8. _____

9. _____

10. _____

11. _____

12. _____

13. _____

STRING NAMES

_ _ _ _

Lesson Two: Whole, Half, and Quarter Note Rhythms

Time signatures appear at the beginning of a piece of music. They are made up of two numbers.



The top number indicates the number of beats per measure.
The bottom number indicates which note will get one beat.

In $\frac{4}{4}$ time there are four beats in each measure.

- A **quarter note** (♩) = 1 beat
- A **half note** (♪) = 2 beats
- A **whole note** (♩) = 4 beats

1. Clap the rhythm while counting the beats out loud.

$\frac{4}{4}$ ♩ ♩ ♩ ♩ | ♩ | ♩ ♩ | ♩ ♩ ♩ ♩ | ♩ ♩ ♩ | ♩ |

1 2 3 4 1 2 3 4 1 2 3 4 1 2 3 4 1 2 3 4 1 2 3 4

2. Write the count below the notes and then clap the rhythm while counting the beats out loud.

$\frac{4}{4}$ ♩ ♩ ♩ ♩ | ♩ ♩ ♩ | ♩ ♩ ♩ ♩ | ♩ ♩ ♩ ♩ | ♩ ♩ | ♩ |

Rests are used in music to indicate silence.

- A **quarter rest** (⏏) = 1 beat
- A **half rest** (▬) = 2 beats
- A **whole rest** (▬) = 4 beats

$\frac{4}{4}$ ⏏ ⏏ ⏏ ⏏ | ▬ ▬ | ▬ |

1 2 3 4 1 2 3 4 1 2 3 4

3. Write the count below the rests.

$\frac{4}{4}$ ⏏ ⏏ ⏏ ⏏ | ▬ | ▬ ▬ | ⏏ ⏏ ⏏ ⏏ | ▬ ⏏ ⏏ | ▬ |

4. Write the count below the notes and rests, then clap and count the rhythm out loud.

$\frac{4}{4}$ ♩ ♩ ▬ | ⏏ ⏏ ♩ ♩ | ♩ ▬ | ▬ | ♩ ♩ ♩ ⏏ | ⏏ ♩ ♩ |

Rhythm Clap and Count #1

Write the count below the notes and rests.

Clap the rhythms while counting out loud.

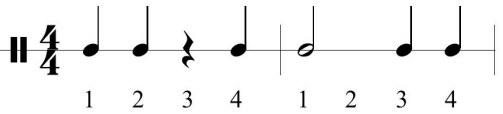
Example 

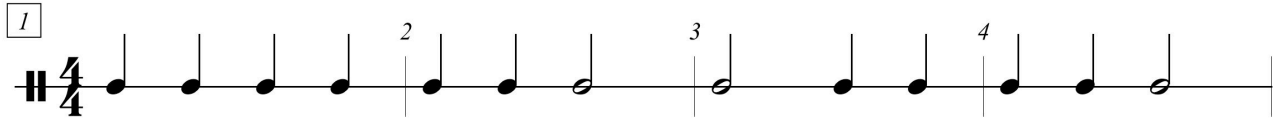
1 

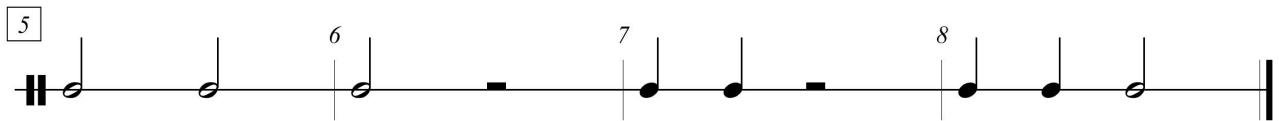
5 

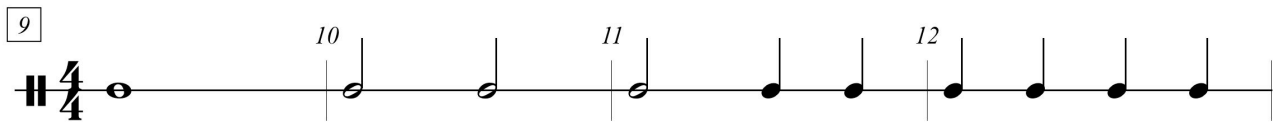
9 

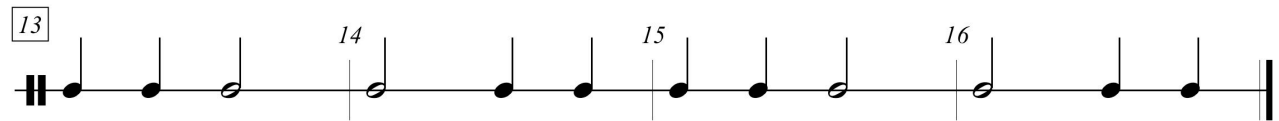
13 

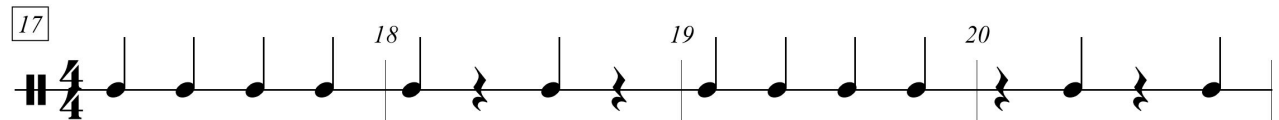
17 

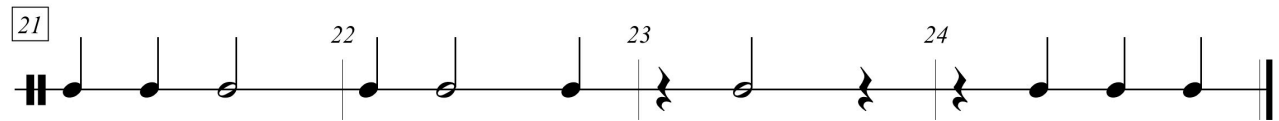
21 

25 

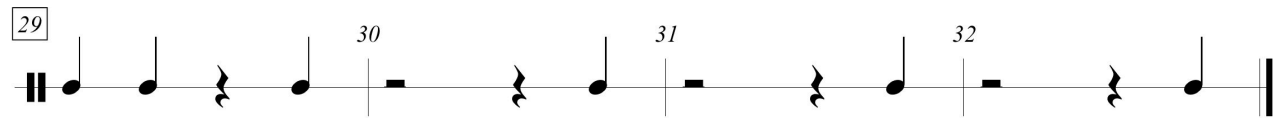
29 

Lesson Three: Open Strings

Music Symbols

<p> = Bass Clef</p> <p> = Bar Line (divides the music into sections called "measures")</p> <p> = Double Bar (the end of the song)</p> <p>⏏ = Quarter Rest (one beat of silence)</p> <p>■ = Half Rest (two beats of silence)</p>	<p>$\frac{4}{4}$ ← how many beats in each measure</p> <p>← which note gets one beat</p>	<p>○ = Whole Note (receives four beats)</p> <p>♩ = Half Note (receives two beats)</p> <p>♪ = Quarter Note (receives one beat)</p>
---	--	---

9. Teeter Totter

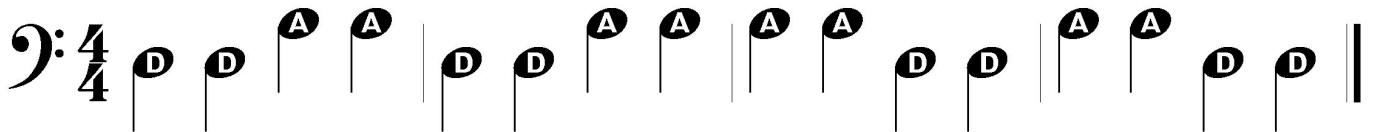

10. Bullfrog

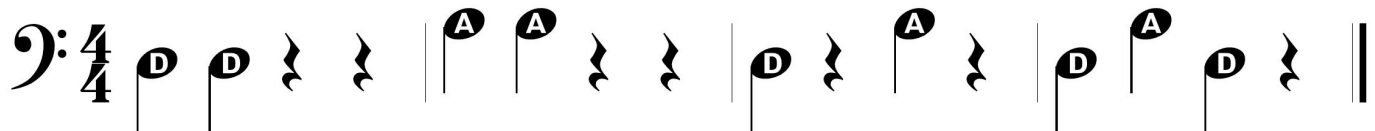

11. Crossing the Strings



12. Skip to my Lou

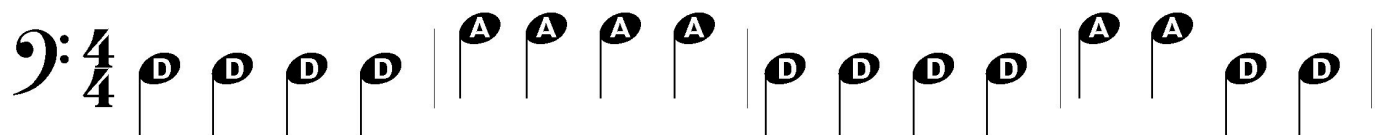

Lesson Three: More Open Strings



13. Mary Had a Little Lamb

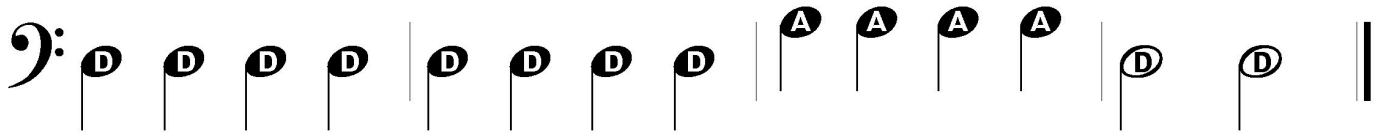
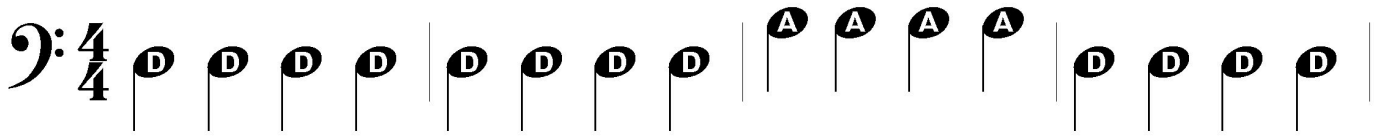

14. Cycle of Strings

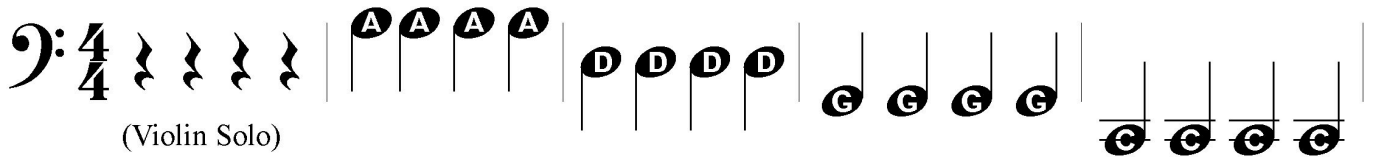

15. Open String Blues

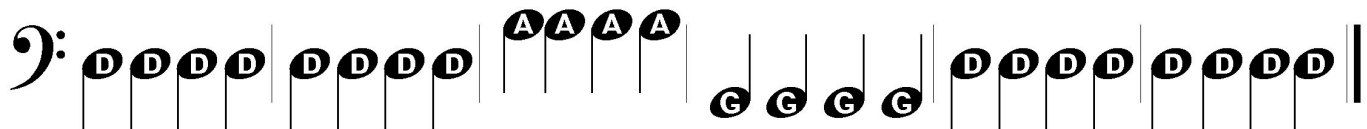
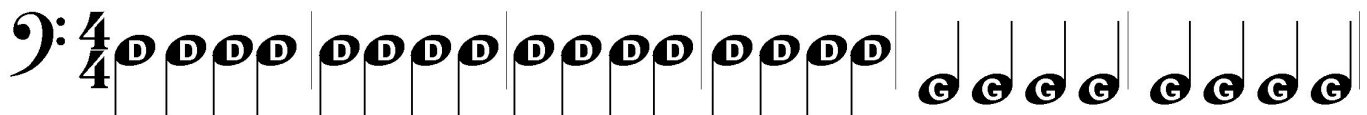

Lesson Four: Using the Bow

Parts of the bow

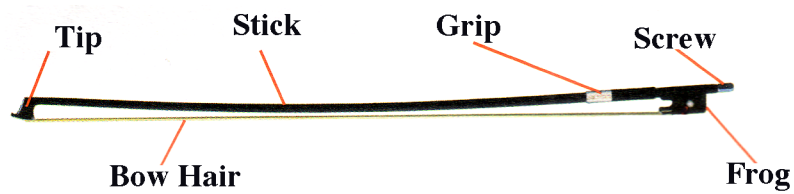

Steps to a good bow hold.....

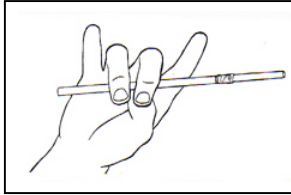

1. Middle fingers curve over the bow stick

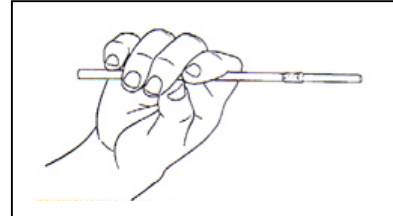

2. Thumb touches where frog meets the stick

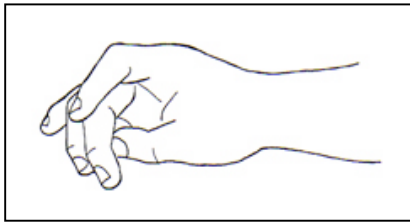

3. Check for bow hand circle

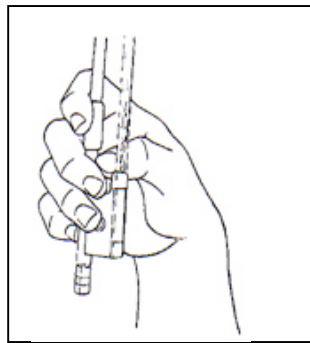

4. Wrap your first finger around the stick.

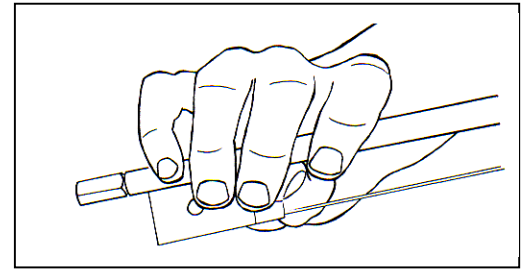

5. Little finger sits on the side of the stick



At first, play in this area of your bow

- Place your bow on the D string, halfway between the bridge and the fingerboard.
- Angle the bow so it is parallel with the bridge (your wrist should be bent upwards.)
- Pull the bow so it remains parallel to the bridge until you reach the tip. (You should need to bend your wrist the other way.)
- Move the bow and your wrist in the opposite direction.



▣ = Down bow (Pull Bow from frog to tip)

∨ = Up Bow (Push Bow from tip to frog)

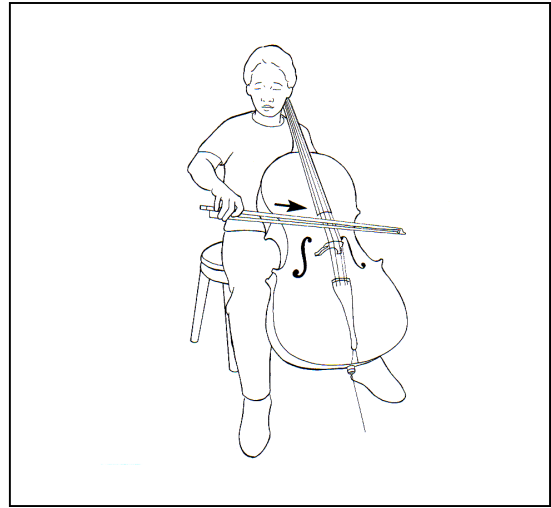
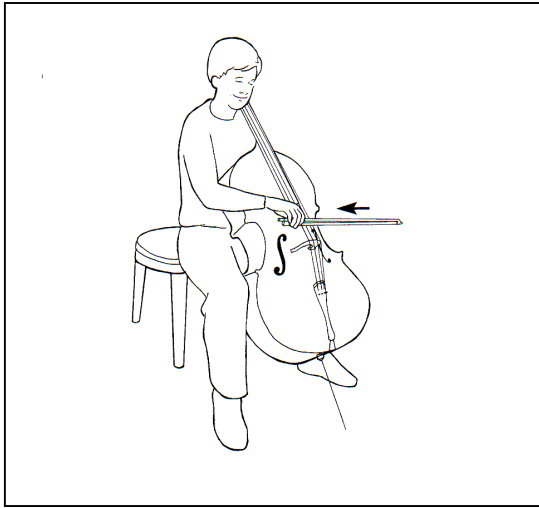

****The bow alternates back and forth unless marking is placed. Orchestra bows should all move together in the same direction.**

16. Bowing on “D”

Bass clef, 4/4 time signature. A sequence of 16 notes on the D string. The notes are grouped into four measures of four notes each. Above each note is a square symbol (▣) for down bow and a V symbol (∨) for up bow, alternating every two notes. The notes are marked with a 'D'.

17. Bowing on “A” - Tilt the bow to the A String

Bass clef, 4/4 time signature. A sequence of 16 notes on the A string. The notes are grouped into four measures of four notes each. Above each note is a square symbol (▣) for down bow and a V symbol (∨) for up bow, alternating every two notes. The notes are marked with an 'A'.

18. Alternate “DNA” - Tilt the bow from the D String to the A String

Changing Strings: Your elbow is responsible for changing strings.

Bass clef, 4/4 time signature. A sequence of 16 notes alternating between the D and A strings. The notes are grouped into two lines of four notes each. The first line starts with a D note, followed by an A note, then D, then A. The second line starts with a D note, followed by an A note, then D, then A. Above each note is a square symbol (▣) for down bow and a V symbol (∨) for up bow, alternating every two notes. The notes are marked with 'D' or 'A'.

Bowing on Open Strings Review

19. "D" Smooth One

Bass clef, 4/4 time. Starts with a square bowing symbol over a D note, followed by a V bowing symbol over a D note. The exercise consists of a sequence of D notes: two single notes, two pairs of beamed notes, and two single notes.

20. Smooth "A"

Bass clef, 4/4 time. Starts with a square bowing symbol over an A note, followed by a V bowing symbol over an A note. The exercise consists of a sequence of A notes: two single notes, two pairs of beamed notes, and two single notes.

21. D N A

Bass clef. Starts with a square bowing symbol over a D note, followed by a V bowing symbol over a D note. The exercise consists of a sequence of notes: two A notes, two pairs of beamed notes, and two D notes.

22. Teeter Totter

Bass clef, 4/4 time. Starts with a square bowing symbol over a D note, followed by a V bowing symbol over a D note. The exercise consists of a sequence of notes: A, A, D, D, A, A, A, A, D, D, A, A, D, D.

23. Cycle of Strings Encore

Bass clef, 4/4 time. Starts with four rests, then a square bowing symbol over an A note, followed by a V bowing symbol over an A note. The exercise consists of a sequence of notes: A, A, A, A, D, D, D, D, G, G, G, G, G, G, G, G.

(Violin Solo)

Bass clef. The exercise consists of a sequence of notes: G, G, G, G, D, D, D, D, A, A, A, A, followed by four rests.

(Violin Solo)

Lesson Five: "B" on the A String

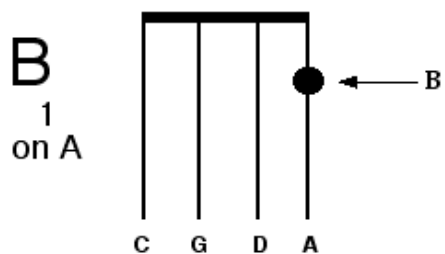

To play "B" on the A string, press the tip of your first finger down securely on the first stripe on the A string.



24. A to B

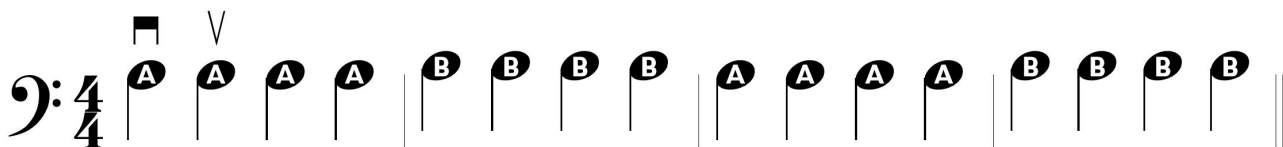

25. Smooth Sailin'

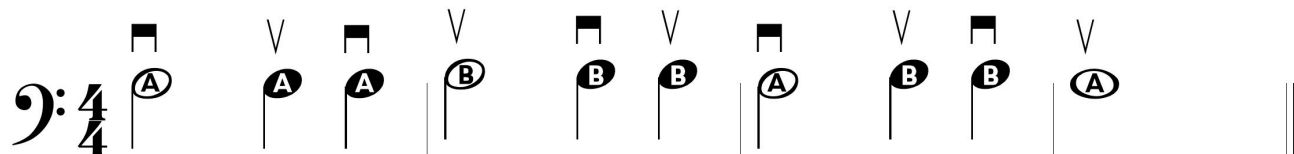

26. Back and Forth

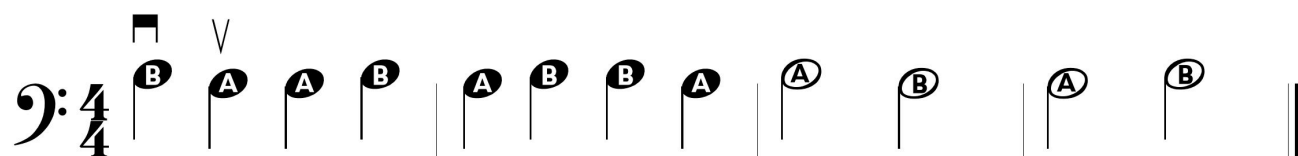

27. Two Note Jive



Lesson Six: C# on the D String

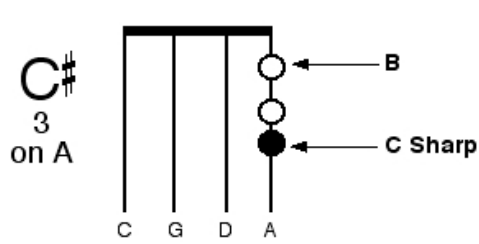

To play C-Sharp, press the tip of your **THIRD** finger on the second stripe on the A string.

Reminder: Keep your first finger on the first stripe and your second finger in between the first and second stripes.

28. Three Note Hill

29. Up and Down

30. Fast and Slow

= half rest (2 beats of silence)

31. Hot Cross Buns

= whole note (receives 4 beats)



✓ 32. Mary Had a Little Lamb

Two staves of musical notation for 'Mary Had a Little Lamb' in bass clef, 4/4 time. The notes are: $\#C^+$, B, A, B, $\#C^+$, C^+ , C^+ , B, B, B, $\#C^+$, C^+ , C^+ on the first staff; and $\#C^+$, B, A, B, $\#C^+$, C^+ , C^+ , C^+ , B, B, $\#C^+$, B, A on the second staff.



= Eighth notes

Each eighth note receives 1/2 of a count

Two eighth notes beamed together = 1 count



33. Mary Doubles

Four staves of musical notation for 'Mary Doubles' in bass clef, 4/4 time. The notes are: $\#C^+$, C^+ (with a 'V' above), B, B, A, A, B, B on the first staff; B, B, B, B, B, B, $\#C^+$, C^+ , C^+ , C^+ , C^+ , C^+ on the second staff; $\#C^+$, C^+ (with a 'V' above), B, B, A, A, B, B on the third staff; B, B, B, B, $\#C^+$, C^+ , A, A, A, A, A, A on the fourth staff.

Eighth Note Rhythms

The rhythmic value of an **eighth notes** is one half of a beat. Eighth notes may be written with a **flag** or a **beam**. If an eighth note appears by itself, it will have a flag. If two or more eighth notes appear in a row, they will often be **beamed** together.

Use a plus sign (+) when writing the count for eighth notes.

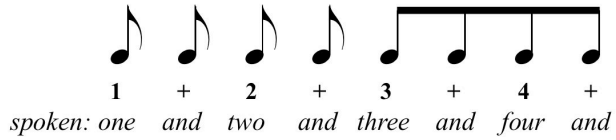

1. Clap the rhythm while counting out loud.



2. Write the count below the notes and then clap the rhythm while counting out loud.

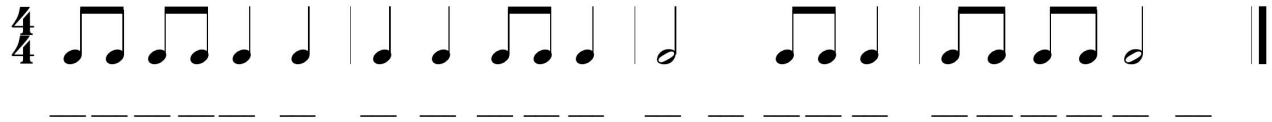

Eighth Note Clap and Count

Write the count below the notes and rests.

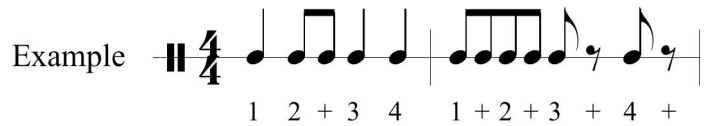

Clap the rhythms while counting out loud.

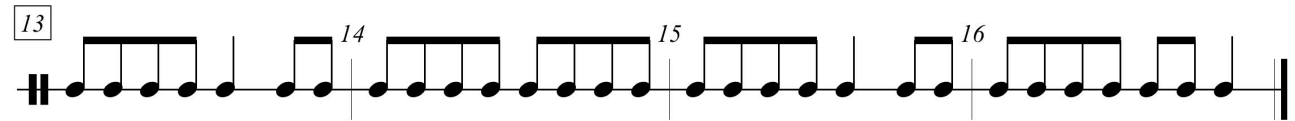
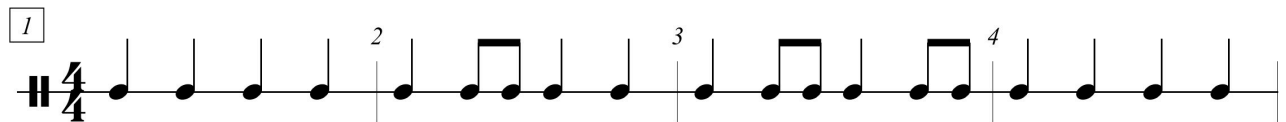

' = Bow Lift
 (lift the bow off the string and reset it at the frog)

34. Claire de Lune

35. Lune de Claire

36. The Reapers

Lesson 7: New Note "High D"

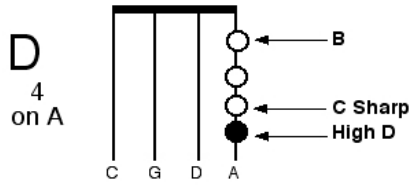

To play High D, press the tip of your fourth finger (pinkie) on the third stripe on the A string.

Reminder: Keep your first three fingers down on the first two stripes.

37. Going Up the A String

38. Going Down the A String

39. Shark Week

40. Bile Them Cabbage Down

|| = repeat sign

go back to beginning
and play again

41. A String Note Review

Match the note with the finger numbers

B

3 on A string

C#

4 on the A string

A

1 on the A string

D

open A string

42. Place a number (1-5) in the blanks to put the 5 steps to a good bow grip in order.

_____ Thumb touches where frog meets the stick

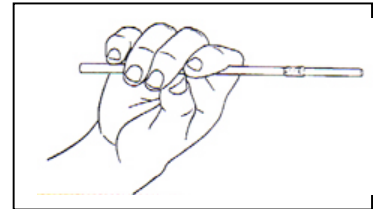

_____ Wrap your fingers around the stick

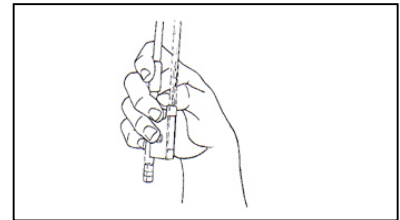

_____ Check for bow hand circle

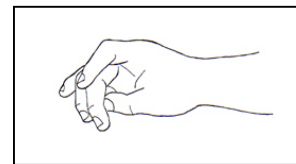

_____ Middle fingers curve over the bow stick

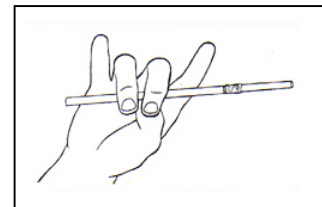

_____ Little finger (pinkie) sits on the side of stick

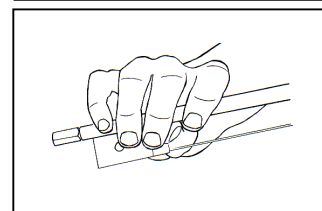

*****Lessons 5, 6, and 7 have been using the notes on the A-String.
All of Lessons 8 and 9 are on the D-String.**

Lesson 8: New Note "E" on the D String

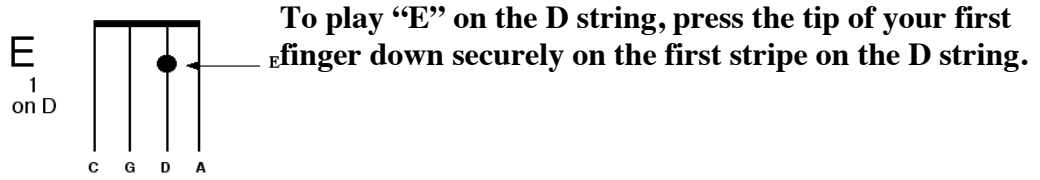

43. ED

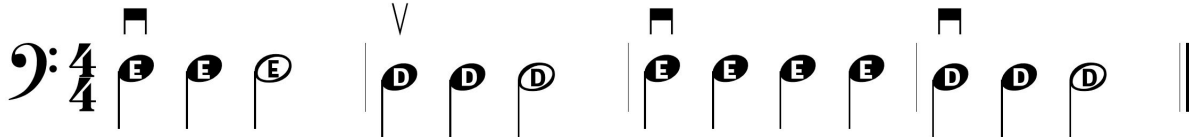

44. First Finger Workout

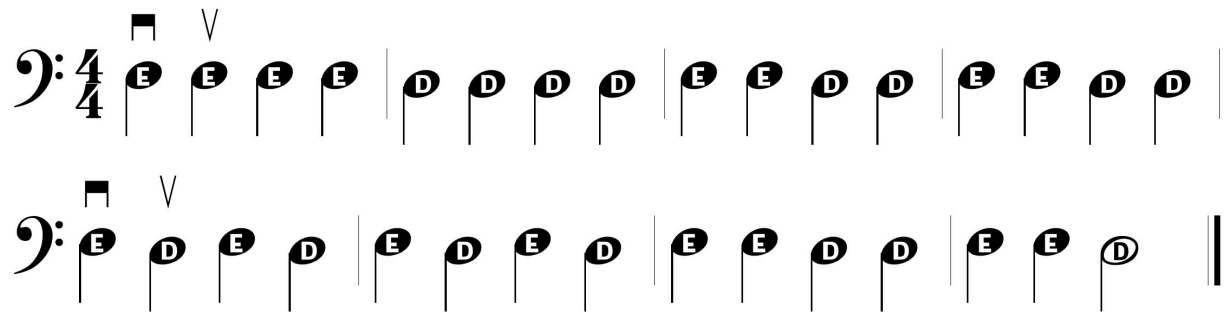

45. Accelerator

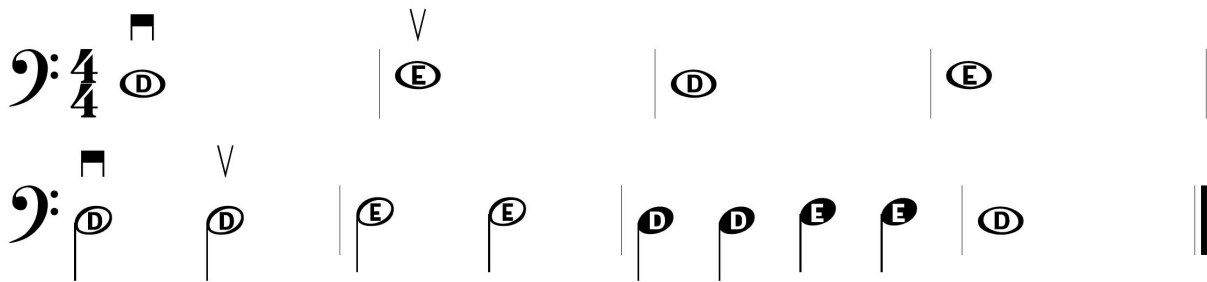

46. Two by Two

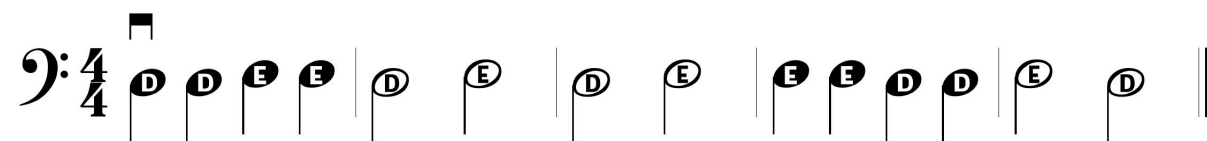

Lesson 9: F# on the D String

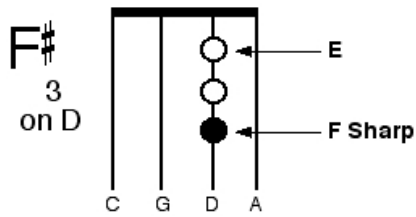

To play F-Sharp, press the tip of your third finger on the second stripe on the D string.

Reminder: Keep your first finger on the first stripe and your second finger in between the first and second stripes.

47. Up and Down

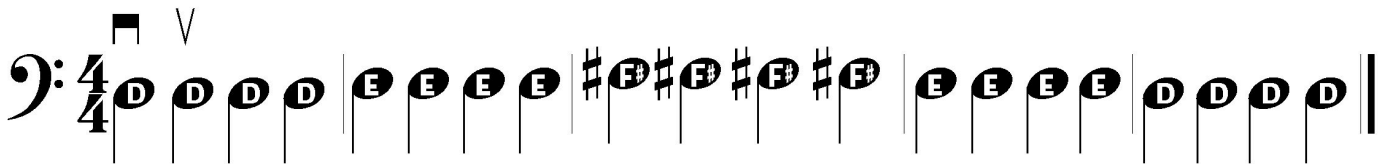

48. Hot Cross Buns on the D String

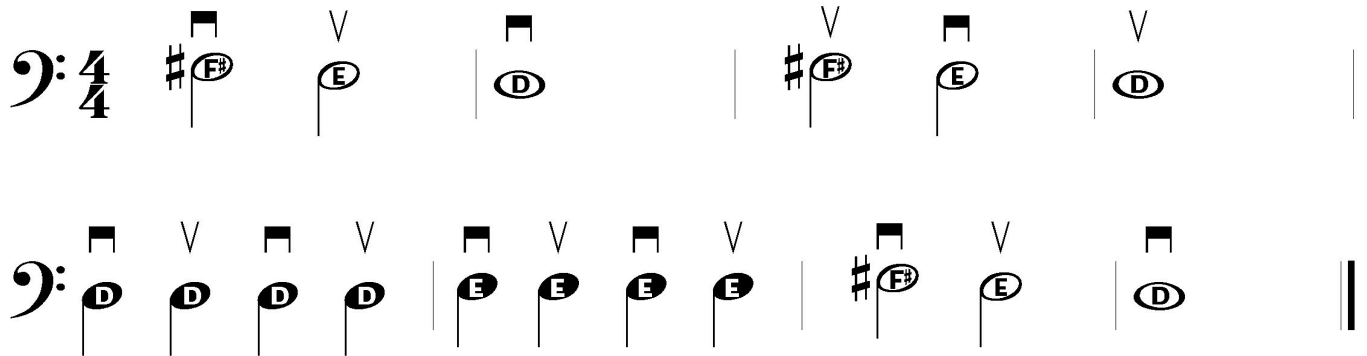

49. Mary Had a Little Lamb on the D String

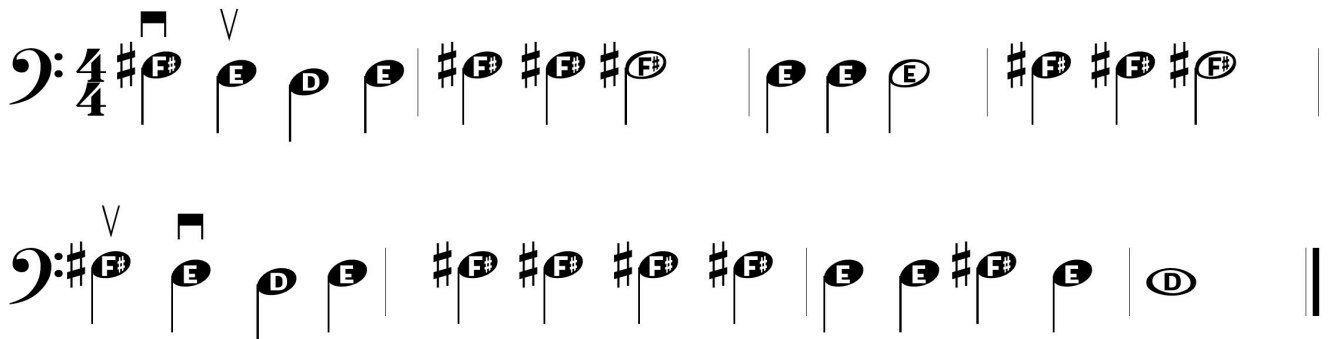

50. Mary Doubles on the D String

51. Claire de Lune

|| = Repeat Sign

Go back to the beginning
and play again

Lesson 10: G on the D String

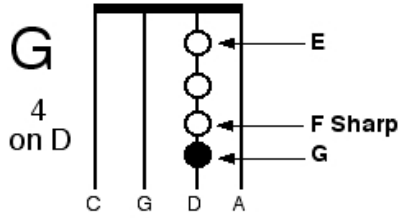

To play G, press the tip of your fourth finger (pinkie finger) on the third stripe. Keep your first three fingers down on the first two stripes on the D String.
KEEP ALL FINGERS DOWN

52. Up the D string

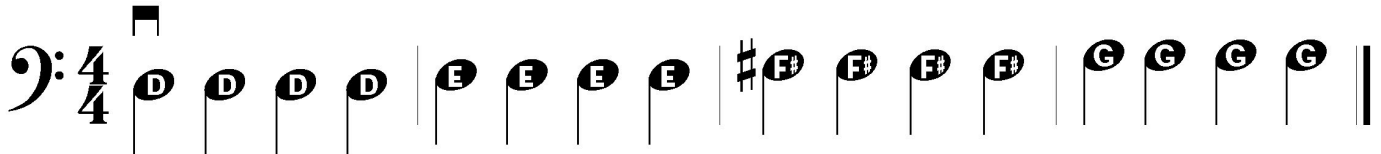

53. Down the D String

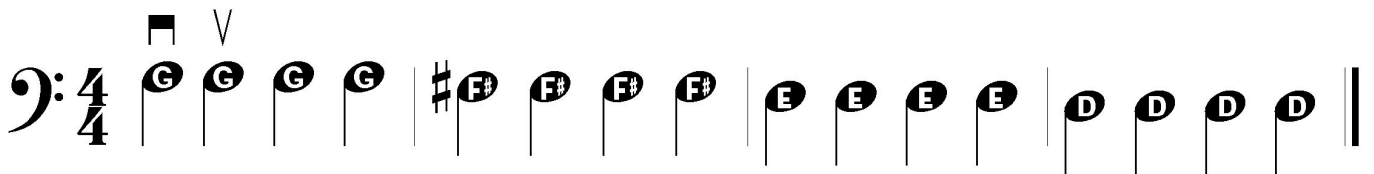

54. Skipping Along the D String

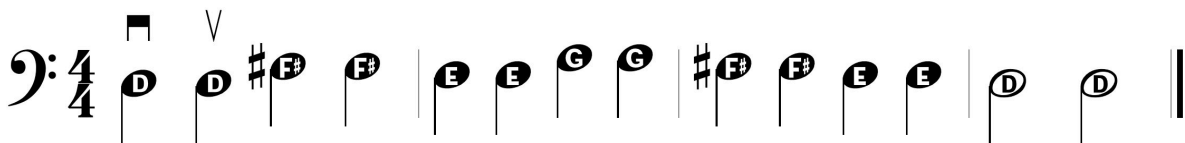

55. Jolly Fellows

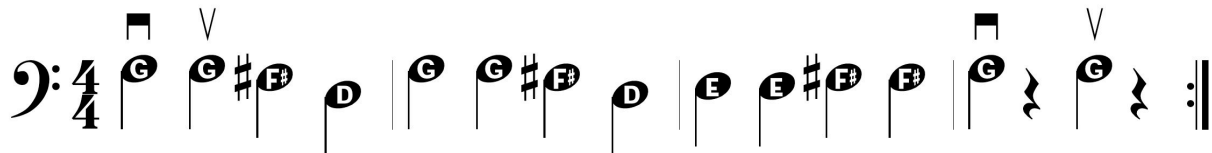

Lesson 11: Crossing Strings

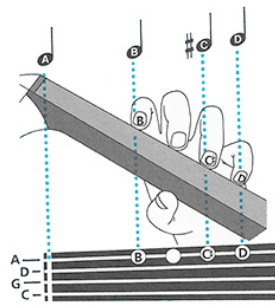
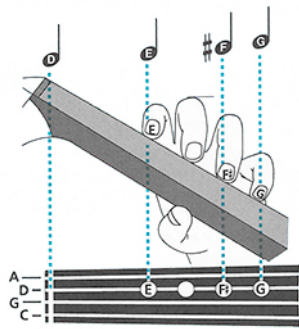

56. Crossing Over

Two staves of music in 4/4 time. The first staff starts with a square and a V symbol above the first two notes. The notes are: A, A, A, A, G, G, G, G, A, A, A, A, G, G, G, G. The second staff contains: A, A, G, G, A, A, G, G, A, G, A, G, A, G, A, G.

57. Ascending the D Scale

Two staves of music in 4/4 time. The first staff starts with a square symbol above the first note. The notes are: D, D, D, D, E, E, E, E, F#, F#, F#, F#, G, G, G, G. The second staff contains: A, A, A, A, B, B, B, B, C#, C#, C#, C#, D, D, D, D.

58. Descending

Two staves of music in 4/4 time. The first staff contains: D, D, D, D, C#, C#, C#, C#, B, B, B, B, A, A, A, A. The second staff contains: G, G, G, G, F#, F#, F#, F#, E, E, E, E, D, D, D, D.

347

✓ 59. Twinkle Twinkle Little Star

Bass clef, 4/4 time signature. The piece consists of three staves of music. The first staff begins with a quarter rest, followed by notes D, D, A, A, B, B, A. The second staff continues with G, G, F#, F#, E, E, D. The third staff repeats the first staff's notes: D, D, A, A, B, B, A, G, G, F#, F#, E, E, D.

✓ 60. Twinkle (Variation)

Bass clef, 4/4 time signature. The piece consists of six staves of music. The first staff has a quarter rest, followed by notes D, D, D, D, D, D, A, B, B, B, B, B, A, A, A, A, A, A. The second staff has G, G, G, G, G, G, F#, F#, F#, F#, F#, F, E, E, E, E, E, E, D, D, D, D, D, D. The third staff has A, A, A, A, A, A, G, G, G, G, G, G, F#, F#, F#, F#, F#, F, E, E, E, E, E, E, E. The fourth staff has A, A, A, A, A, A, G, G, G, G, G, G, F#, F#, F#, F#, F#, F, E, E, E, E, E, E, E. The fifth staff has a quarter rest, followed by notes D, D, D, D, D, D, A, A, A, A, A, A, B, B, B, B, B, B, A, A, A, A, A, A. The sixth staff has G, G, G, G, G, G, F#, F#, F#, F#, F#, F, E, E, E, E, E, E, D, D, D, D, D, D.



✓ 61. French Folk Song

62. Note Review- Write the note names for all the notes you have learned so far

1st finger

3rd finger

4th finger

Name the Strings

✓ 63. Tuneful Tune

✓ 63. Tuneful Tune
 Bass clef, 4/4 time.
 Staff 1: C#4, C#4, A4, A4 | C#4, C#4, C#4
 Staff 2: C#4, C#4, A4, A4 | C#4, C#4, C#4
 Staff 3: B3, B3, B3, B3 | B3, B3, D4
 Staff 4: B3, B3, B3, B3 | A4, A4 (Off (Pluck!))

✓ 64. Ode to Joy

✓ 64. Ode to Joy
 Bass clef.
 Staff 1: F#3, F#3, G3, A3 | A3, G3, F#3, E3 | D3, D3, E3, F#3 | F#3, E3, E3
 Staff 2: F#3, F#3, G3, A3 | A3, G3, F#3, E3 | D3, D3, E3, F#3 | E3, D3, D3
 Staff 3: E3, E3, F#3, D3 | E3, F#3, G3, F#3 | E3, F#3, G3, F#3 | E3, D3, E3, A3
 Staff 4: F#3, F#3, G3, A3 | A3, G3, F#3, E3 | D3, D3, E3, F#3 | E3, D3, D3

Honor 4th Grade String Songs

65. Mary on the A String

Musical notation for 'Mary on the A String' in 4/4 time. The piece is written in two staves. The first staff begins with a treble clef and a key signature of one sharp (F#). The notes are: C# (quarter), B (quarter), A (quarter), B (quarter), C# (quarter), C# (quarter), C# (quarter), B (quarter), B (quarter), B (quarter), C# (quarter), C# (quarter), C# (quarter). The second staff begins with a bass clef and a key signature of one sharp (F#). The notes are: C# (quarter), B (quarter), A (quarter), B (quarter), C# (quarter), C# (quarter), C# (quarter), C# (quarter), B (quarter), B (quarter), C# (quarter), B (quarter), A (quarter).

66. Mary Doubles- (1st Variation)

Musical notation for 'Mary Doubles- (1st Variation)' in 4/4 time. The piece is written in four staves. The first staff begins with a treble clef and a key signature of one sharp (F#). The notes are: C# (quarter), C# (quarter), B (quarter), B (quarter), A (quarter), A (quarter), B (quarter), B (quarter), C# (quarter), C# (quarter), C# (quarter), C# (quarter), C# (quarter), C# (quarter), C# (quarter), C# (quarter). The second staff begins with a bass clef and a key signature of one sharp (F#). The notes are: B (quarter), B (quarter), B (quarter), B (quarter), B (quarter), B (quarter), B (quarter), B (quarter), C# (quarter), C# (quarter), C# (quarter), C# (quarter), C# (quarter), C# (quarter), C# (quarter), C# (quarter). The third staff begins with a treble clef and a key signature of one sharp (F#). The notes are: C# (quarter), C# (quarter), B (quarter), B (quarter), A (quarter), A (quarter), B (quarter), B (quarter), C# (quarter), C# (quarter), C# (quarter), C# (quarter), C# (quarter), C# (quarter), C# (quarter), C# (quarter). The fourth staff begins with a bass clef and a key signature of one sharp (F#). The notes are: B (quarter), B (quarter), B (quarter), B (quarter), C# (quarter), C# (quarter), B (quarter), B (quarter), A (quarter), A (quarter), A (quarter), A (quarter), A (quarter), A (quarter), A (quarter), A (quarter).

67. Twinkle Twinkle, Little Star

Musical notation for 'Twinkle Twinkle, Little Star' in 4/4 time. The piece is written in three staves. The first staff begins with a treble clef and a key signature of one sharp (F#). The notes are: D (quarter), D (quarter), A (quarter), A (quarter), B (quarter), B (quarter), A (quarter), G (quarter), G (quarter), F# (quarter), F# (quarter), E (quarter), E (quarter), D (quarter). The second staff begins with a bass clef and a key signature of one sharp (F#). The notes are: A (quarter), A (quarter), G (quarter), G (quarter), F# (quarter), F# (quarter), E (quarter), A (quarter), A (quarter), G (quarter), G (quarter), F# (quarter), F# (quarter), E (quarter). The third staff begins with a treble clef and a key signature of one sharp (F#). The notes are: D (quarter), D (quarter), A (quarter), A (quarter), B (quarter), B (quarter), A (quarter), G (quarter), G (quarter), F# (quarter), F# (quarter), E (quarter), E (quarter), D (quarter).

68. Twinkle Variation

69. French Folk Song

70. Ode to Joy





Bass clef, 4/4 time signature. The piece consists of four staves of music. The first two staves show the main melody with notes F#, F#, G, A, A, G, F#, E, D, D, E, F#, F#, E, E. The third and fourth staves show variations and endings with notes E, E, F#, D, E, F#, G, F#, D, E, F#, G, F#, E, D, E, A.

71. Tuneful Tune



Bass clef, 4/4 time signature. The piece consists of four staves of music. The first two staves show the main melody with notes C#, C#, A, A, C#, C#, C#. The third and fourth staves show variations and endings with notes B, B, B, B, B, B, D, B, B, B, B, A, B, B, B, B, A, A.

Some Basic Rhythmic Fundamentals







Note Values

Quarter Note		= one beat
Half Note		= two beats
Dotted Half Note		= three beats
Whole Note		= four beats

Rest Values

Quarter Rest		= one beat
Half Rest		= two beats
Whole Rest		= four beats

72. Quiz

1. A  _____ receives _____ beats.
2. A  _____ receives _____ beats.
3. A  _____ receives _____ beats.
4. A  _____ receives _____ beats.
5. A  _____ receives _____ beats.
6. A  _____ receives _____ beats.
7. A  _____ receives _____ beats.

Directions: Match each note to the number of beats it gets

	1
	2
	3
	4

String Instrument Word Search



- | | | | | | |
|--------------|--------------|-------------|-------------|------------|----------------|
| alto clef | arco | barline | bass clef | bow | bow grip |
| bow lift | bridge | cello | chin rest | double bar | down bar |
| down bow | end button | fine tuners | fingerboard | frog | half note |
| half rest | measure | melody | neck | notes | pizzicato |
| quarter note | quarter rest | repeat sign | rhythm | rosin | scroll |
| sharp | shoulder pad | sound holes | tailpiece | tempo | time signature |
| treble clef | tuning pegs | up bow | viola | violin | whole note |
| whole rest | | | | | |

Reading Music

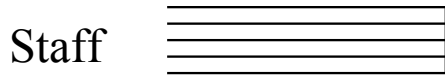

A music staff has five lines and four spaces.



The bass clef is located at the beginning of every staff and tells us this music is for cello and other low pitched instruments.



The top number tells us how many beats are in each measure. The bottom number tells us which kind of note receives one beat.

Rhythm Chart

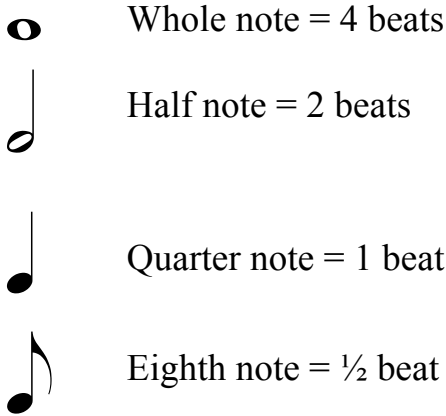

4 Steps to Success

1. Count and clap the rhythms.
2. Clap and sing the note names.
3. Sing note names and shadow bow.
4. Play.

Note Name and Fingering Reference Chart

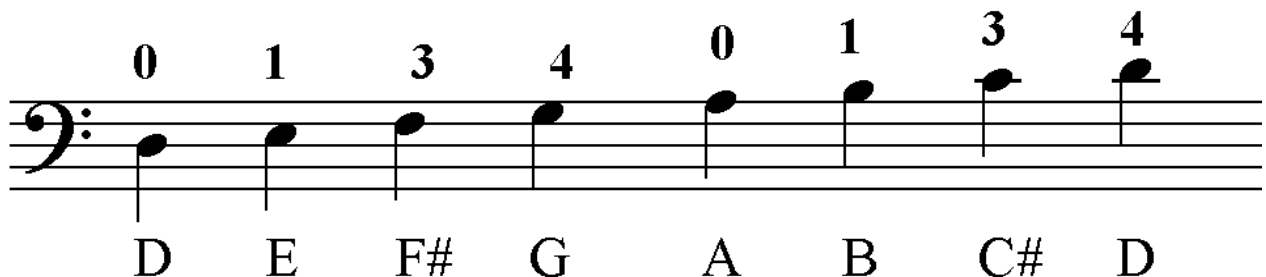

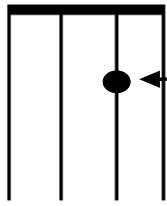

E on the D String

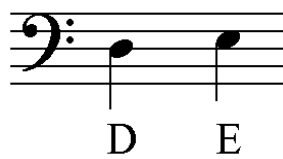

E is located on the third space.
Open D is located on the third line.



73. First Finger March



74. Flash-E First



75. Mix Em Up



76. ED Takes a Stroll

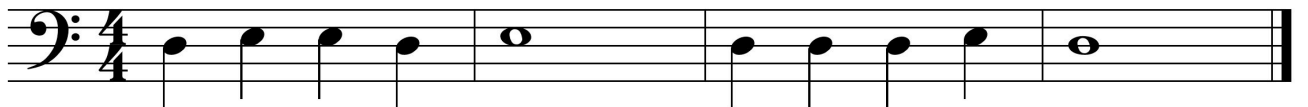

77. Diz-E-Dog

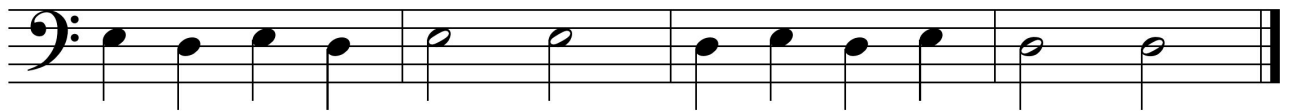

There are four counts in each measure. Write each count in the correct space. Start each measure with count one.

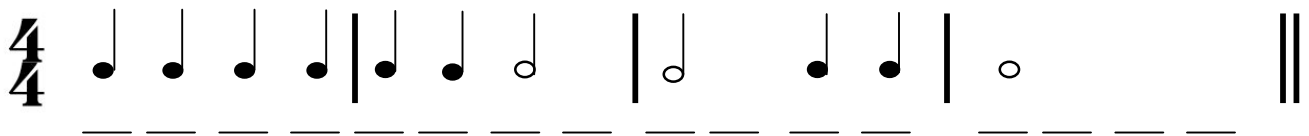

F# on the D String

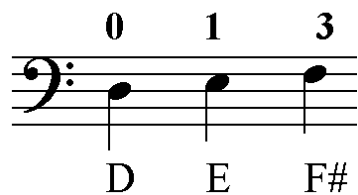
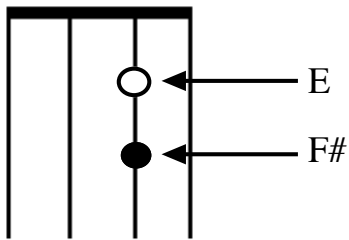

F# is located on the fourth line.
 E is located on the third space.
 Open D is located on the third line.



78. New Note F#

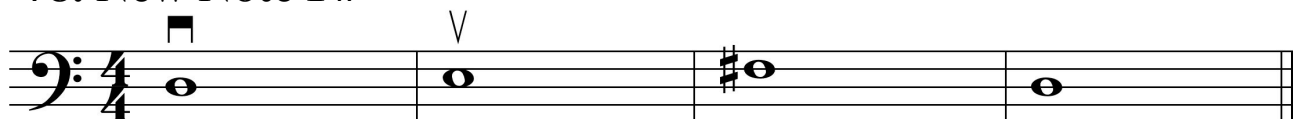

79. Let's Read F#



80. Climbing Up

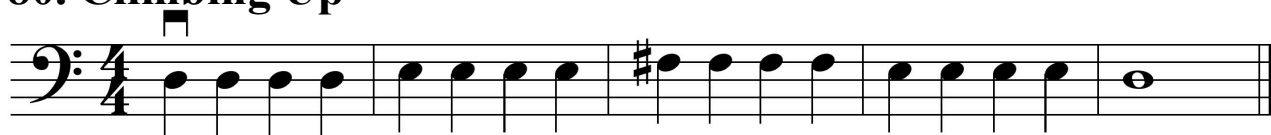

81. Black and White



⏏ = A Quarter Rest is one beat of silence.

82. Resting

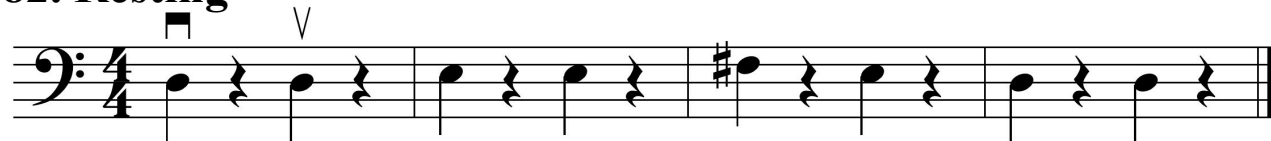

83. Walking Song



F# Tunes



’ Bow lift Lift bow off of the string and reset at the frog.



84. The Reapers



85. Skip-A-Long



86. Claire de Lune



87. Lune de Claire

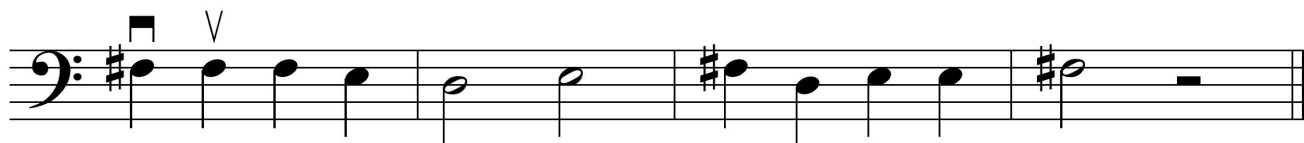

More F# Tunes

88. Write the note names on the lines below

0 1 3



89. Name That Tune _____

90. Name That Tune _____

91. Peter's Hammer

G on the D String

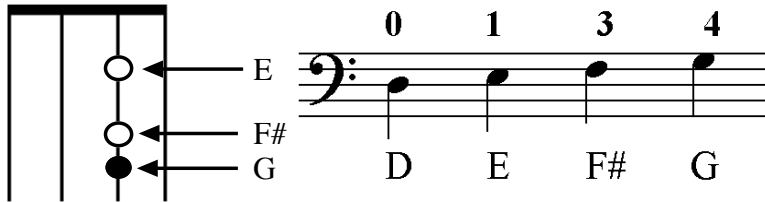

G is located on the fourth space.

F# is located on the fourth line.

E is located on the third space.

Open D is located on the third line.



92. Three Plus G

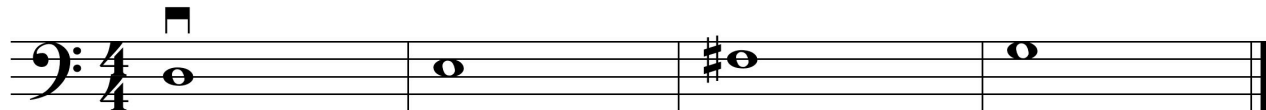

93. Going Up and Down

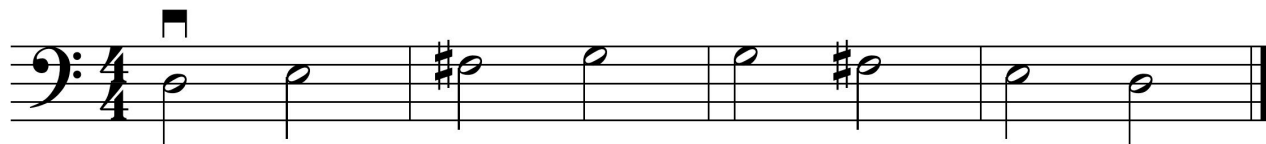

94. Go, Go, Go

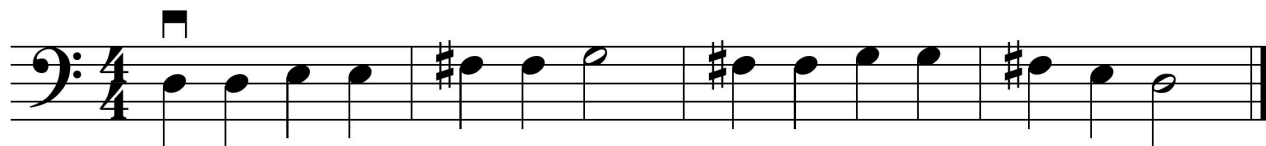

95. Grasshoppers



96. Norwegian Folk Song



97. Pizzicato March



G Tunes



KEY SIGNATURE



In this *key signature* you will play all F's as F#'s and all C's as C#'s. The *key signature* is always located at the beginning of each line. You will notice that there are no longer any sharps located in the songs.



98. Cockroaches



99. Speed Bump



(Lift)



100. Clown Dance (Play 3 Times)

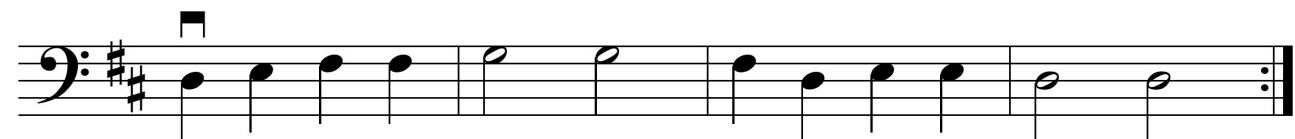

101. Write the correct note letter name under each note

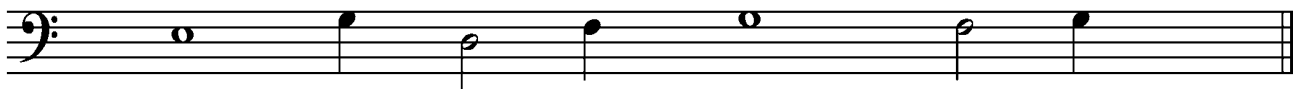

1. _____ 2. _____ 3. _____ 4. _____ 5. _____ 6. _____ 7. _____

102. Draw four E quarter notes 2. Draw four F# quarter notes 3. Draw two G half notes

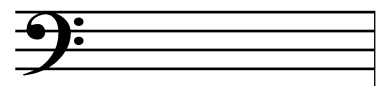
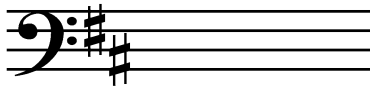
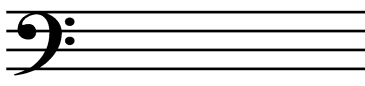

Crossing Strings: New Note A



E 0 1 3 4 0
 F# D E F# G A
 G

A is located on the fifth line.

G is located on the fourth space.

F# is located on the fourth line.

E is located on the third space.

Open D is located on the third line.

103. More DNA

104. Crossing Over

105. Climbing to A

106. Merry Dance

A Tunes



107. Jingle Bells

Sheet music for "Jingle Bells" in bass clef, 4/4 time, key of D major. The music consists of four staves. The first staff begins with a treble clef and a 4/4 time signature. The melody is written in bass clef. The key signature has two sharps (F# and C#). The music features a mix of quarter and eighth notes, with some rests. There are several dynamic markings, including accents (^) and breath marks (v). The piece ends with a double bar line.

108. Skipping Around

Sheet music for "Skipping Around" in bass clef, 4/4 time, key of D major. The music consists of one staff. The melody is written in bass clef. The key signature has two sharps (F# and C#). The music features a mix of quarter and eighth notes, with some rests. There are several dynamic markings, including accents (^). The piece ends with a double bar line.

109. Lightly Row

Sheet music for "Lightly Row" in bass clef, 4/4 time, key of D major. The music consists of four staves. The melody is written in bass clef. The key signature has two sharps (F# and C#). The music features a mix of quarter and eighth notes, with some rests. There are several dynamic markings, including accents (^) and breath marks (v). The piece ends with a double bar line.

B on the A String

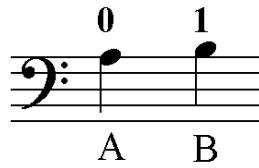
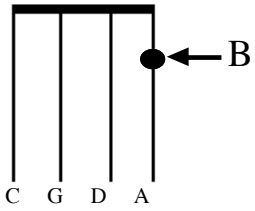

B is located on top of the music staff.
Open A is located on the fifth line.



110. A to B

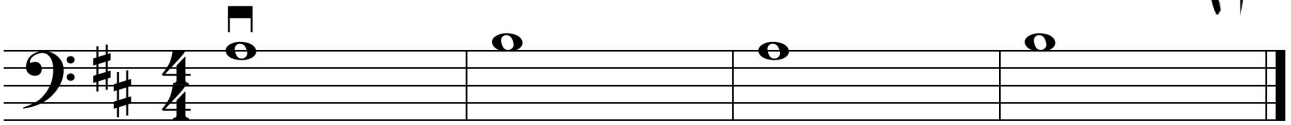



111. Apples and Bananas



112. Old MacDonald



 = Each eighth note is half of a beat. Two eighth notes equal one beat.

Ex: 

1 & 2 & 3 & 4 & 1 & 2 & 3 & 4 &

4. Count and Clap

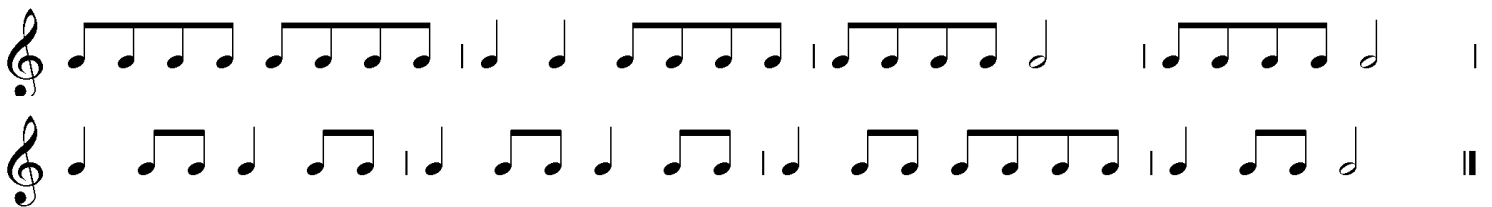

113. Baa Baa Black Sheep

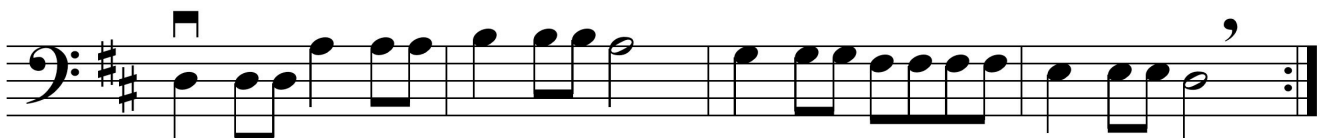

C# on the A String

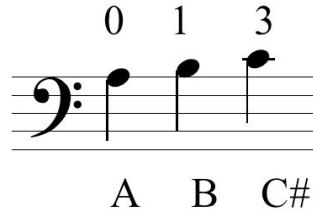
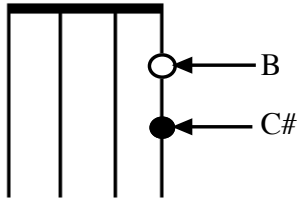

C# is located on the first ledger line.
B is located on top of the music staff.
Open A is located on the fifth line.

114. My A-B-C-'s



115. Apples, Bananas, and Cherries



116. Merry Go Round



117. Go Tell Aunt Rhodie



118. Name That Tune

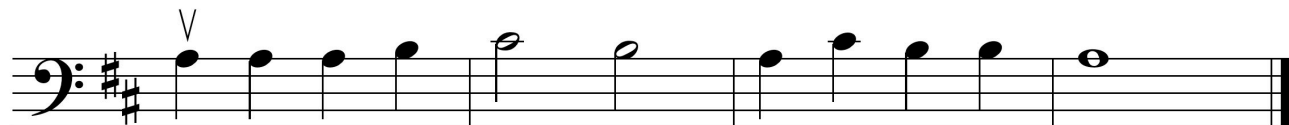

D on the A String

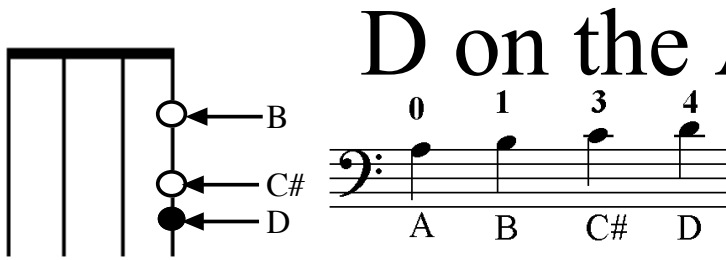

B
 C#
 D

0 1 3 4
 A B C# D



D is located on top of the first ledger line.
C# is located on the first ledger line.
B is located on top of the music staff.
Open A is located on the fifth line.

119. Reaching for High D

120. Donkey Song

121. Rockin' on the A String

122. D Major Scale and Arpeggio

D Tunes



A Repeat Sign tells you to repeat the music.



123. School March

Musical notation for 'School March' in bass clef, D major, 4/4 time. It consists of four staves. The first staff starts with a repeat sign. The melody is simple and rhythmic, ending with a fermata on the final note.

124. Bohemian Folk Song

Musical notation for 'Bohemian Folk Song' in bass clef, D major, 4/4 time. It consists of two staves. The first staff has a repeat sign and a fermata on the final note. The second staff continues the melody with a repeat sign at the end.

125. Scotland's Burning

Musical notation for 'Scotland's Burning' in bass clef, D major, 4/4 time. It consists of two staves. The first staff has a repeat sign and a first ending bracket labeled '1.'. The second staff has a second ending bracket labeled '2.' and a third ending bracket labeled '3.'.

126. Camptown Races

Four staves of musical notation for the piece 'Camptown Races'. The music is written in bass clef with a key signature of two sharps (F# and C#) and a 4/4 time signature. The notation includes eighth and sixteenth notes, rests, and various ornaments such as 'V' marks and square flags above notes. The piece concludes with a double bar line.

127. Can Can

Four staves of musical notation for the piece 'Can Can'. The music is written in bass clef with a key signature of two sharps (F# and C#) and a 4/4 time signature. The notation features a mix of eighth and sixteenth notes, with some notes marked with 'V' ornaments and square flags. The piece ends with a double bar line.

Hoedown

CELLO

1

2

3

4

5

6

7

8

9

10

11

12

13

14

15

16

17

18

19

20

21

22

23

24

25

26

27

28

29

30

31

32

+

Honor Songs

Mary Had a Little Lamb

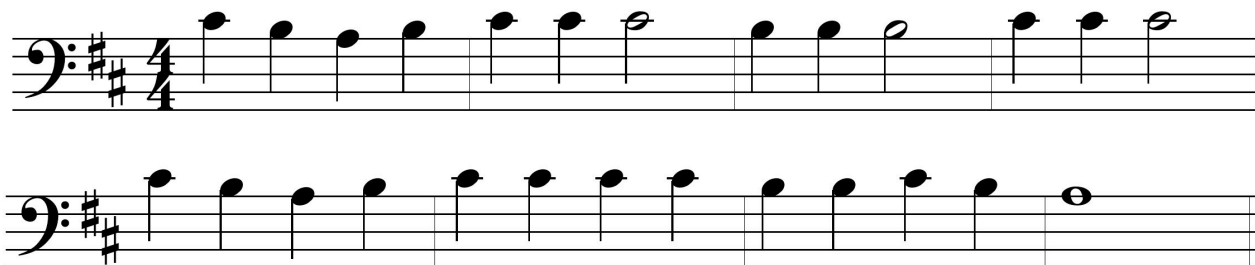

Mary Doubles

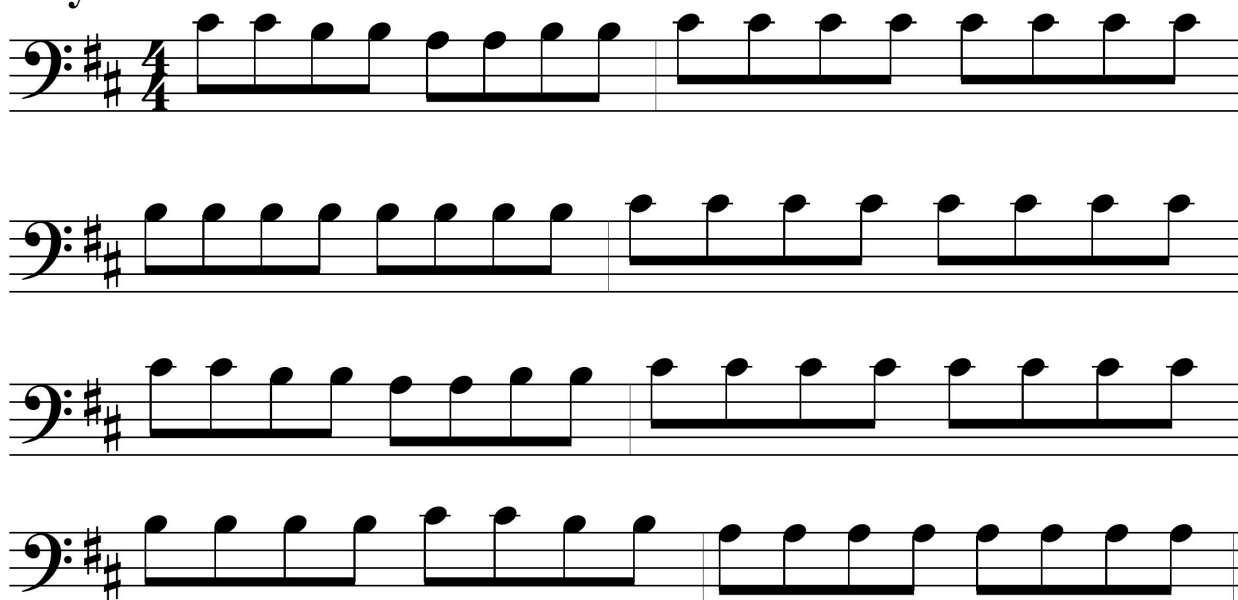

Twinkle, Twinkle Little Star

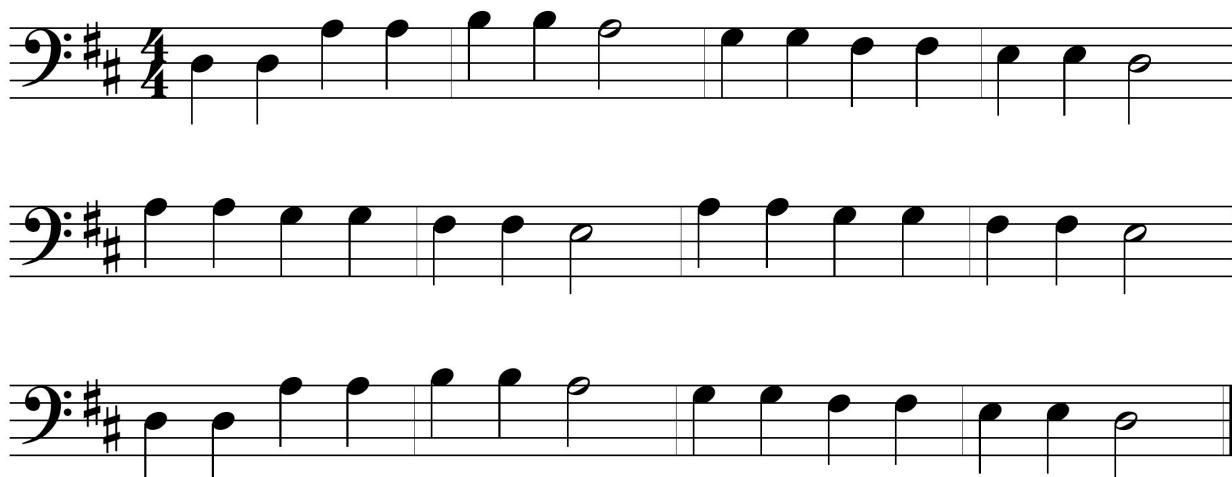

Twinkle Variation

Musical score for "Twinkle Variation" in bass clef, key of D major (two sharps), and 4/4 time. The piece consists of six staves of music. The first staff begins with a treble clef and a 4/4 time signature. The melody is a variation of the "Twinkle, Twinkle, Little Star" tune, featuring eighth-note patterns and slurs. The notation includes various rhythmic values such as eighth notes, quarter notes, and half notes, with some notes beamed together. The piece concludes with a double bar line.

French Folk Song

Musical score for "French Folk Song" in bass clef, key of D major (two sharps), and 3/4 time. The piece consists of five staves of music. The melody is a simple folk tune, primarily composed of quarter notes and half notes. The notation includes various rhythmic values such as quarter notes, half notes, and dotted half notes. The piece concludes with a double bar line.

Ode to Joy

Musical score for "Ode to Joy" in bass clef, 4/4 time, key of D major. The score consists of four staves of music. The first staff is a simple melody. The second and fourth staves include "V" (pluck) and square (finger) markings above notes. The third staff includes "V" and square markings above notes and slurs under groups of notes.

Tuneful Tune

Musical score for "Tuneful Tune" in bass clef, 4/4 time, key of D major. The score consists of four staves of music. The first staff is a simple melody. The second, third, and fourth staves include "V" (pluck) and square (finger) markings above notes. The fourth staff includes "off (pluck)" markings above notes.

Glossary of Terms

Accidentals (#, ♮, ♭): sharp, natural, and flat symbols for altering pitch.

Arco: to play using the bow.

Arpeggio: notes of a chord played separately.

Beat: the pulse of the music.

Bow lanes: point of contact of the bow, near the bridge or near the fingerboard.

Bow lift: lift the bow from the string and return to the frog in a circular motion.

Clef sign: located at the beginning of each line of music, the clef sign defines the letter names for the lines and spaces on the staff for your instrument.

Col legno: or more precisely col legno battuto ([Italian](#) for "hit with the wood"), is an instruction to strike the string with the stick of the bow.

Down bow: moving bow toward tip; pull.

Duet: music in two parts.

Fermata: symbol indicating to hold a note longer.

Key signature: identifies notes that are raised or lowered.

Ledger lines: extend the staff with small lines written above or below.

Legato: play with smooth bow strokes.

Measure: the space between barlines.

Octave: a pitch that is eight notes higher or lower and both pitches have the same letter name.

Pizzicato (*pizz.*): pluck the string with the index finger of the right hand.

Repeat sign: go back and play a section of music again.

Scale: a set of eight notes in ascending or descending order that begins and ends on the same letter.

Spiccato: bowing technique for string instruments in which the bow bounces lightly upon the string.

Staccato: stopped bow stroke.

Staff: 5 lines and 4 spaces, used for writing music.

Time signature: indicates how many beats are in a measure (top number) and what kind of note gets one beat (bottom number).

Tremolo: shake the bow back and forth rapidly as if trembling.

Up bow: moving bow toward frog; push.

Note Name and Fingering Reference Chart



Glossary Crossword Puzzle

Please complete the crossword puzzle below using the terms and definitions from the glossary.

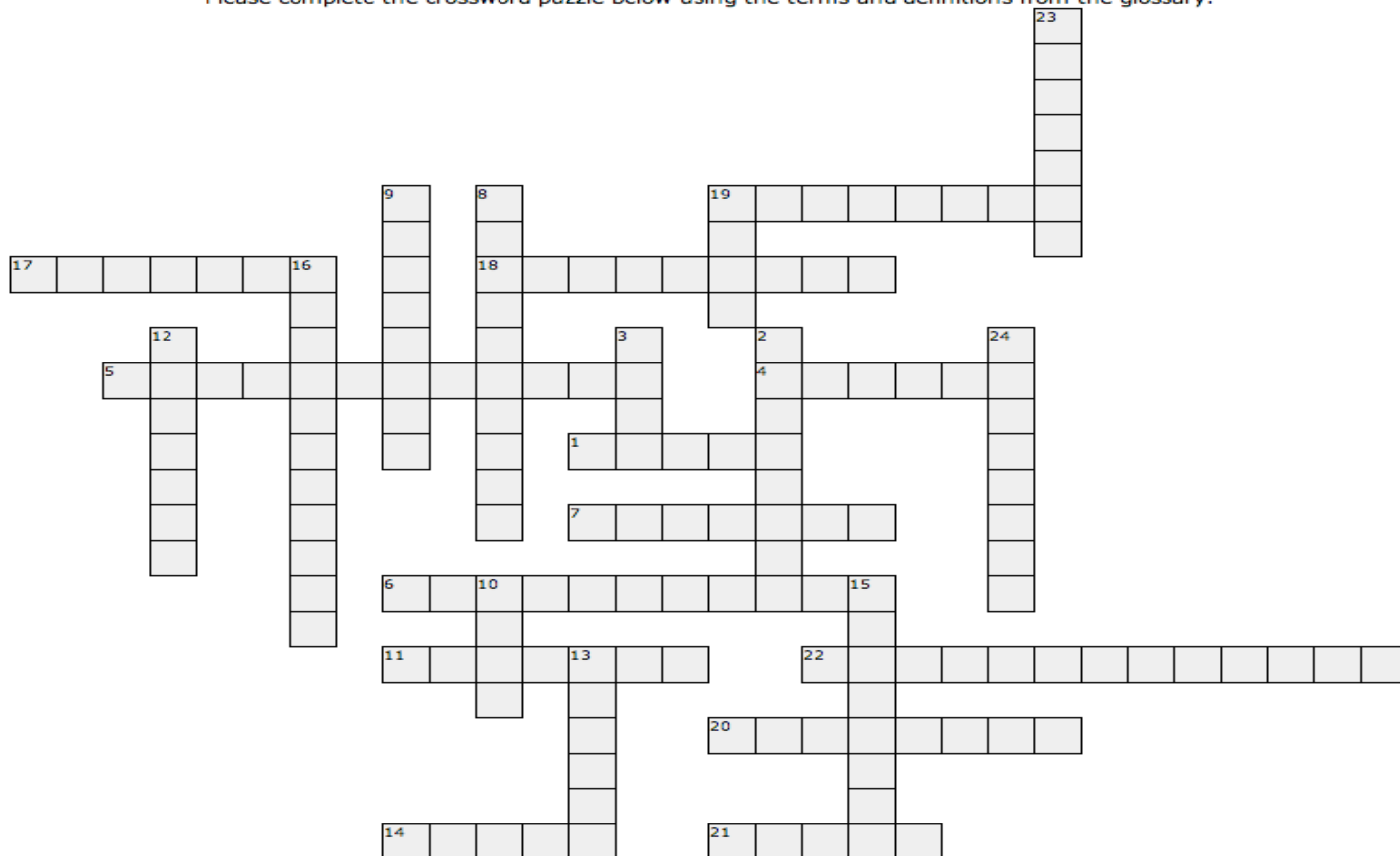

Across:

1. 5 lines and 4 spaces, used for writing music
4. play with smooth bow strokes
5. identifies notes that are raised or lowered (2 words)
6. extend the staff with small lines written above or below (2 words)
7. lift the bow from the string and return to the frog in a circular motion (2 words)
11. shake the bow back and forth rapidly as if trembling
14. a set of eight notes in ascending or descending order that begins and ends on the same letter
17. symbol indicating to hold a note longer
18. pluck the string with the index finger of the right hand
19. notes of a chord played separately
20. stopped bow stroke
21. moving the bow toward frog; push (2 words)
22. indicates how many beats are in a measure (top number) and what kind of note receives one beat (bottom number) (2 words)

Down:

2. located at the beginning of each line of music, this symbol defines the letter names for the lines and spaces on the staff for your instrument (2 words)
3. the pulse of the music
8. go back and play a section of music again (2 words)
9. points of contact of the bow, near the bridge or near the fingerboard (2 words)
10. music in two parts
12. the space between barlines
13. a pitch that is eight notes higher or lower and both pitches have the same letter name
15. bowing technique for string instruments in which the bow bounces lightly upon the string.
16. sharp, natural, and flat symbols for altering pitch
19. to play using the bow
23. moving bow toward tip; pull (2 words)
24. an instruction to strike the string with the stick of the bow (2 words)

Complete the Story

1 2 3 4 5 6 7

8 9 10 11 12

13 14 15

Each group of notes spells a word. Use the words to fill in the blanks in the following story. The number "1" group spells the word for the number "1" blank, the number "2" group spells the word for the number "2" blank, and so on.

_____ (1) and her mom and _____ (2) were moving into a new home at the _____ (3) of town. It was their last night in the old house. Everything was moved out except a _____ (4), some _____ (5), and a sleeping _____ (6). _____ (7) said, "It sure is _____ (8) around here." She _____ (9) to have a party that last night, but _____ (10) said it was a _____ (11) time to have friends over, and, too it was late. Mom _____ (12) that there was no way she could _____ (13) anyone, so a party was out. Just then the door flew open. There were Ruthie, _____ (14) and _____ (15) standing in the doorway, yelling "Surprise!" Each carried a _____ (16) filled with goodies. They also brought paper plates and cups. There was even a jug of lemon _____ (17). What started out as a dull evening turned out to be a fun time for all.

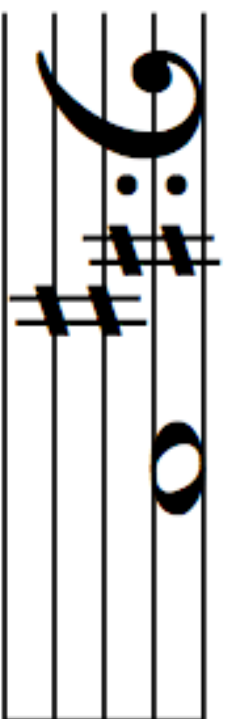
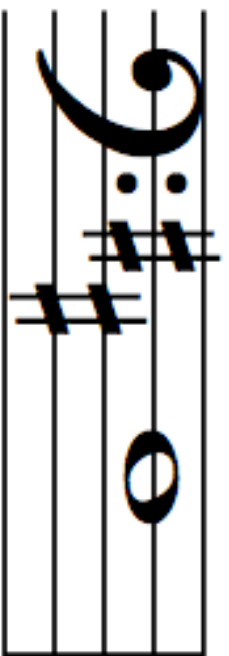
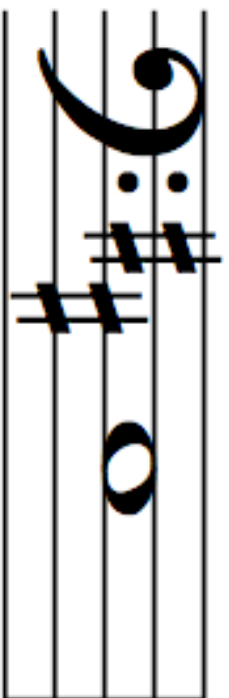
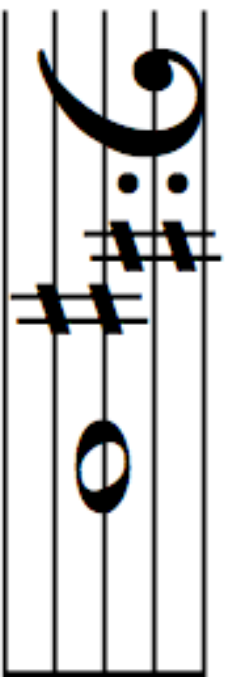

Flashcards for the D String Notes
Cut out and use to practice your note names.

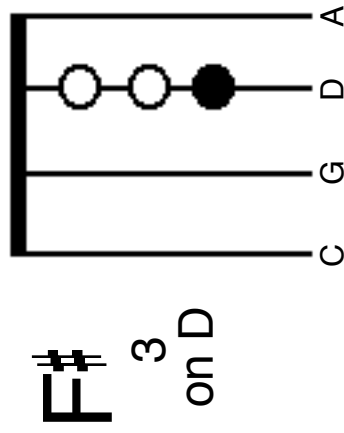
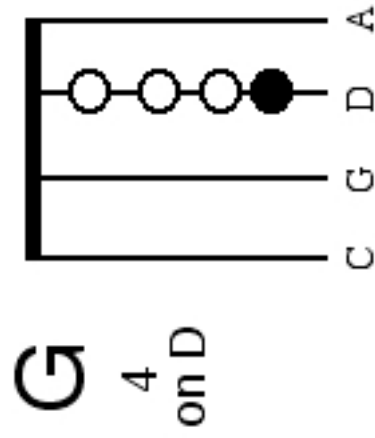
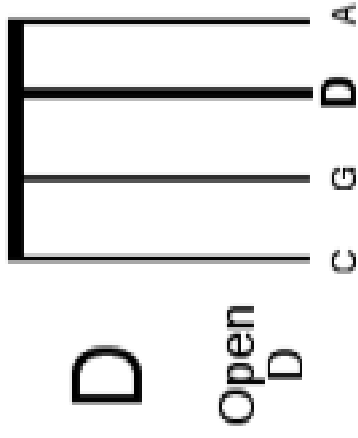
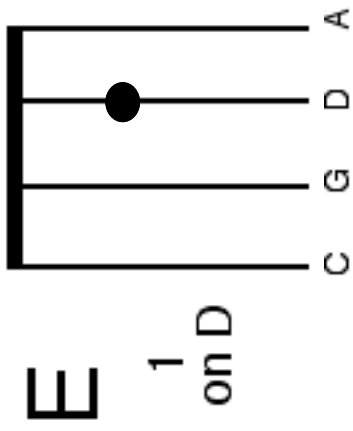

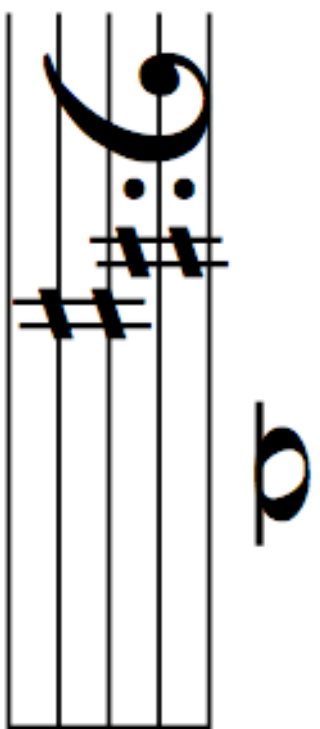
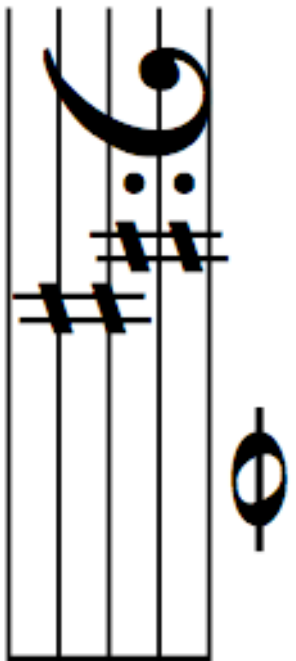
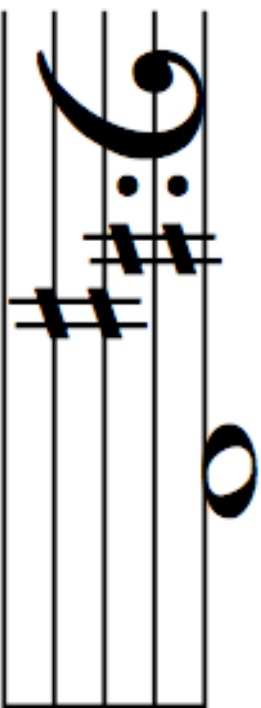
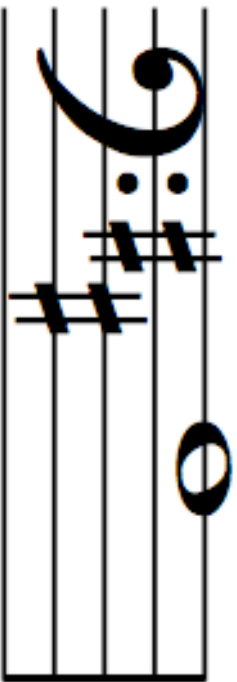

Flashcards for the A String Notes
Cut out and use to practice your note names.

